

Mobile XL Height & Tilt Adjustable Trolley

The Mobile XL Height & Tilt Adjustable Trolley is an electrical height adjustable trolley that offers two separate 350mm height adjustment options, providing flexibility and versatility. It has a C-shaped mobile stand equipped with four heavy-duty castors, two of which have brakes for stability. The display mount is designed to accommodate screens up to 65" with a maximum load capacity of 150kg, providing reliable support for screens of various weights and sizes. Suitable for ages 2-16+ (approximate body size 930-2070+mm).



Mobile XL Height & Tilt Adjustable Trolley Specifications

Features

Minimum height	655mm (Centre Screen)
Maximum height	1355mm (Centre Screen)
Colour	Black
Maximum load	150kg approx
Mobile/fixed	Mobile
Height adjustment	Electric - 500mm
Bracket/interface	Included
Type bracket/interface	VESA
Range bracket/interface	VESA 200 x 200 up to 800 x 600

Accessories

Side shelf, Lockable wall bracket

Packing Units

Item No.	Description	Packing dimensions (mm)	Net weight (kg)	Gross weight (kg)
CCET-3535B	Electrical height adjustable column, 2 x 350mm height adjustment, L = 585mm	820 x 270 x 220	21,2	24,0
AF-SCETTA	Display mount	890 x 770 x 480	22,1	26,8
MST-SCETA-CB	C-shaped mobile stand	1350 x 780 x 120	12,8	15,5
Total Weight			55,7	66,3

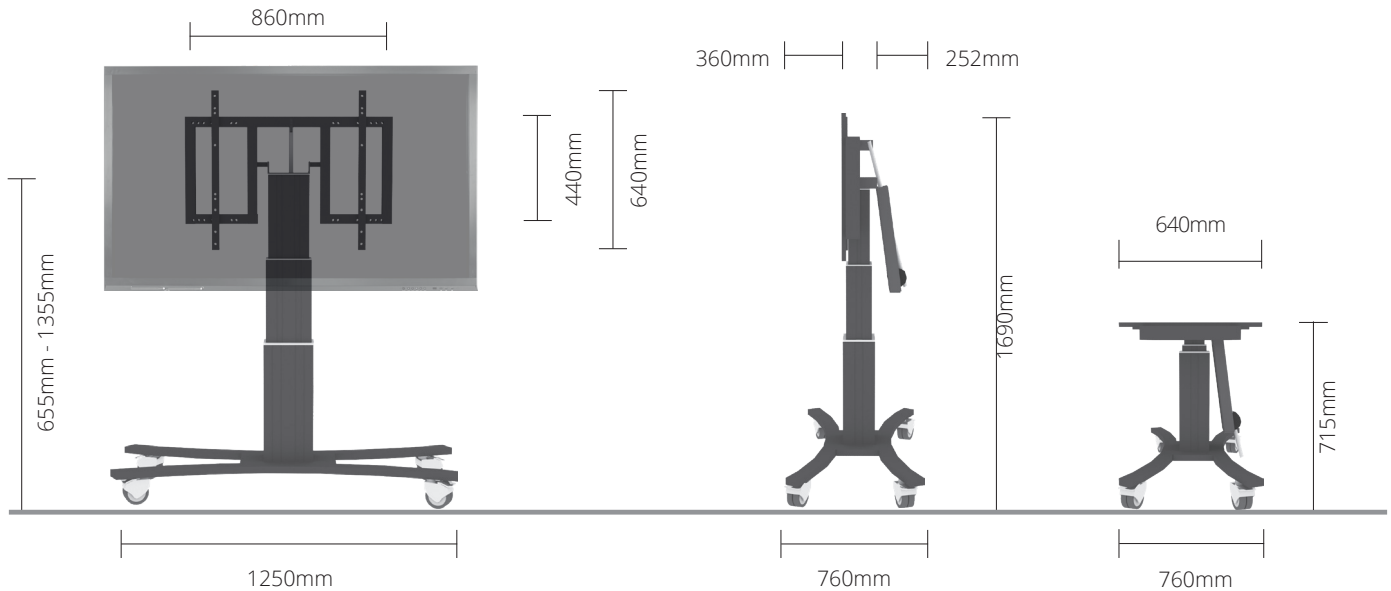

Statement

Size and weight vary by configuration and manufacturing process, please refer to the actual product. The product images are for illustrative purposes only and may slightly differ in appearance, colour, size, etc. from the actual product. The description, illustrations, etc. in this document may subject to change in accordance with the latest product specification and performance. Should the above-mentioned change in the document become necessary, the document may be updated without written notice.

© 2021 Clevertouch. All rights reserved. Sahara Presentations Systems PLC. is part of the Boxlight group of companies, and the owner of trademarks in several global jurisdictions including but not limited to Clevertouch, the Clevertouch logo, UX Pro, IMPACT™, IMPACT Plus™, Impact MAX, CleverLive, LUX, Lynx, CleverMessage, Cleverstore and Clevershare. All third-party trademarks (including logos and icons) referenced by Clevertouch remain the property of their respective owners. Unless specifically identified as such, Clevertouch's use of third-party trademarks does not indicate any relationship, sponsorship, or endorsement between Clevertouch and the owners of these trademarks. Applicable Terms and Conditions for warranty and support available at clevertouch.com/about/warranty. All weights and dimensions are approximate. Product specifications are subject to change without notice. Clevertouch.com.